

Ташев-Галвинг ООД
www.tashev-galving.com

PLUS 3P and 2P filter housings
for cartridges SX



FILTER HOUSINGS

PLUS 3P and 2P for cartridges SX

PLUS SX is a full range of housings designed to fit to standard SX (DOE) cartridges with height from 4" to 20". The housings are made in 2 main versions:

- **3P** housings for cartridge height at 5", 7", 10", 20".
- **2P** housings for cartridge height at 4", 7", 10".

All 3P and 2P housings are available as single and DUPLEX models.

With In/Out configurations at 1/2", 3/4" and 1", with BSP or NPT threads, with or without brass inserts, PLUS SX housings are suitable for every Point-of-Entry (POE) application, as single or multi-stage on-line filters.

PLUS SX housings are manufactured with the finest and most advanced materials under constant focus

on innovative processing technologies and ceaseless modernization to ensure the absolute quality of our products.

The housings are certified under the most stringent certification procedures and standards: TIFQ (Italy), ACS (France), ANSI/NSF (USA), GOST (Russia).

All models are available with clear and opaque blue bowls. Custom combinations of colors are available upon minimum quantity.

A full set of accessories is available on demand to complete the housings kit: wall brackets, opening spanner, diffuser tubes and brass or plastic nipples with o-ring.

HOUSINGS PLUS SX

FOR CARTRIDGES SX

Housings PLUS SX fit to standard SX (DOE) cartridges.

The full range of Atlas Filtri® SX cartridges is suitable to PLUS SX housings and provide the widest range of water filtration and treatment units.



SX cartridges with standard flat seals.

CERTIFICATIONS



A range of housings is tested and certified by WQA against NSF/ANSI Standards 42 and 61 for material safety and structural integrity requirements only. In compliance with drinking water regulations, USA.



The products are tested and certified under the most stringent procedures worldwide, achieving the certification of compliance with DM 174/2004 (TIFO Italy), the sanitary certifications ACS (France) and GOST (Russia).

ACCESSORIES ON DEMAND



-U- spanner CODE RB7403013



-S- wall bracket CODE RB7400007



-D- wall bracket CODE RB7400009



3/4" brass nipples with o-ring (pair) CODE RB7404001

1" brass nipples with o-ring (pair) CODE RB7404002



3/4" plastic nipple with o-ring CODE LB9020612



3/4"-1/4" plastic reduction with o-ring CODE LB9020611



4" diffuser tubes CODE LB7405012

5" diffuser tubes CODE LB7405003

7" diffuser tubes CODE LB7405004

10" diffuser tubes CODE LB7405005

SYMBOLS LEGEND



For domestic use











For technical and industrial use

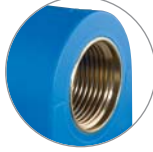
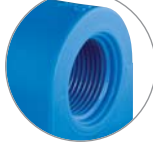
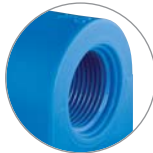
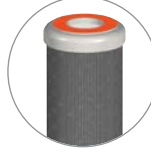

Filter housings made in PET, a highly recyclable plastic, are manufactured with a proprietary procedure saving up to 60% of energy in injection molding compared with standard plastics. That is one of Atlas Filtri commitments to comply with Kyoto Treaty for the reduction of green house gas (CO₂) emissions in the atmosphere.

HOUSINGS RANGE



SENIOR	PLUS	3P	A	FO	SX	TS
HOUSINGS MODEL	VERSION	IN / OUT	THREADS TYPE	CARTRIDGE TYPE	BOWL TYPE	
<ul style="list-style-type: none"> CADET DUPLEX MEDIUM DUPLEX JUNIOR DUPLEX SENIOR DUPLEX MASTER DUPLEX 	<ul style="list-style-type: none"> PLUS PLUS M  	<ul style="list-style-type: none"> 3P 2P  	<ul style="list-style-type: none"> M 1/2" A 3/4" B 1" 	<ul style="list-style-type: none"> FO - BRASS BSP * FP - PLASTIC BSP * FP-NPT - PLASTIC NPT **   	<ul style="list-style-type: none"> SX - STANDARD FLAT SEALS 	<ul style="list-style-type: none"> TS - CLEAR (PET) AS - CLEAR (SAN) AB - BLUE (PET)   

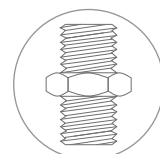

* BSP
parallel (cylindrical)
ISO 228

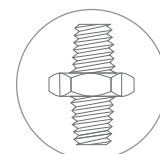

** NPT
tapered (conical)
ANSI/ASME B1.20.1



PLUS 3P SX

WORKING CONDITIONS

Max working pressure _____ 8 bar (116 psi)
 Max working temperature _____ 45°C (113°F)

SPECIFICATIONS

Non-toxic materials, suitable for drinking water.
 Head and ring nut: reinforced polypropylene.
 Bowl: PET.
 O-ring: EPDM.
 Breather-valve: body polypropylene, o-ring EPDM.
 IN/OUT brass threads: CW 614 N brass.

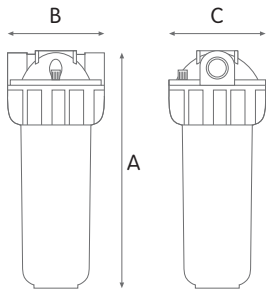

PLUS 3P SX clear housings

HOUSINGS WITH BRASS BSP THREADS

CODE	MODEL	SUITABLE CARTRIDGE	IN/OUT	THREADS	DIMENSIONS mm		
					A	B	C
RA107T111	MEDIUM PLUS 3P MFO SX TS	5"	1/2"	BRASS-BSP	191	133	130
RA107T411	MEDIUM PLUS 3P AFO SX TS	5"	3/4"	BRASS-BSP	191	133	130
RA107T711	MEDIUM PLUS 3P BFO SX TS	5"	1"	BRASS-BSP	197	145	130
RA109T111	JUNIOR PLUS 3P MFO SX TS	7"	1/2"	BRASS-BSP	241	133	130
RA109T411	JUNIOR PLUS 3P AFO SX TS	7"	3/4"	BRASS-BSP	241	133	130
RA109T711	JUNIOR PLUS 3P BFO SX TS	7"	1"	BRASS-BSP	247	145	130
RA111T111	SENIOR PLUS 3P MFO SX TS	10"	1/2"	BRASS-BSP	315	133	130
RA111T411	SENIOR PLUS 3P AFO SX TS	10"	3/4"	BRASS-BSP	315	133	130
RA111T711	SENIOR PLUS 3P BFO SX TS	10"	1"	BRASS-BSP	321	145	130
RA115T111	MASTER PLUS 3P MFO SX TS	20"	1/2"	BRASS-BSP	571	133	130
RA115T411	MASTER PLUS 3P AFO SX TS	20"	3/4"	BRASS-BSP	571	133	130
RA115T711	MASTER PLUS 3P BFO SX TS	20"	1"	BRASS-BSP	577	145	130

HOUSINGS WITH PLASTIC BSP THREADS

CODE	MODEL	SUITABLE CARTRIDGE	IN/OUT	THREADS	DIMENSIONS mm		
					A	B	C
RA107T211	MEDIUM PLUS 3P MFP SX TS	5"	1/2"	PLASTIC-BSP	191	133	130
RA107T511	MEDIUM PLUS 3P AFP SX TS	5"	3/4"	PLASTIC-BSP	191	133	130
RA107T811	MEDIUM PLUS 3P BFP SX TS	5"	1"	PLASTIC-BSP	197	145	130
RA109T211	JUNIOR PLUS 3P MFP SX TS	7"	1/2"	PLASTIC-BSP	241	133	130
RA109T511	JUNIOR PLUS 3P AFP SX TS	7"	3/4"	PLASTIC-BSP	241	133	130
RA109T811	JUNIOR PLUS 3P BFP SX TS	7"	1"	PLASTIC-BSP	247	145	130
RA111T211	SENIOR PLUS 3P MFP SX TS	10"	1/2"	PLASTIC-BSP	315	133	130
RA111T511	SENIOR PLUS 3P AFP SX TS	10"	3/4"	PLASTIC-BSP	315	133	130
RA111T811	SENIOR PLUS 3P BFP SX TS	10"	1"	PLASTIC-BSP	321	145	130
RA115T211	MASTER PLUS 3P MFP SX TS	20"	1/2"	PLASTIC-BSP	571	133	130
RA115T511	MASTER PLUS 3P AFP SX TS	20"	3/4"	PLASTIC-BSP	571	133	130
RA115T811	MASTER PLUS 3P BFP SX TS	20"	1"	PLASTIC-BSP	577	145	130

HOUSINGS WITH PLASTIC NPT THREADS

CODE	MODEL	SUITABLE CARTRIDGE	IN/OUT	THREADS	DIMENSIONS mm		
					A	B	C
RA107T513	MEDIUM PLUS 3P AFP NPT SX TS	5"	3/4"	PLASTIC-NPT	191	133	130
RA107T813	MEDIUM PLUS 3P BFP NPT SX TS	5"	1"	PLASTIC-NPT	197	145	130
RA109T513	JUNIOR PLUS 3P AFP NPT SX TS	7"	3/4"	PLASTIC-NPT	241	133	130
RA109T813	JUNIOR PLUS 3P BFP NPT SX TS	7"	1"	PLASTIC-NPT	247	145	130
RA111T610	SENIOR PLUS 3P AFP NPT SX TS	10"	3/4"	PLASTIC-NPT	315	133	130
RA111T611	SENIOR PLUS 3P BFP NPT SX TS	10"	1"	PLASTIC-NPT	321	145	130
RA115T611	MASTER PLUS 3P AFP NPT SX TS	20"	3/4"	PLASTIC-NPT	571	133	130
RA115T813	MASTER PLUS 3P BFP NPT SX TS	20"	1"	PLASTIC-NPT	577	145	130

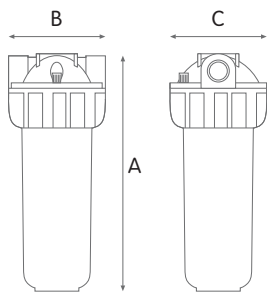

WORKING CONDITIONS

Max working pressure _____ 8 bar (116 psi)
 Max working temperature _____ 45°C (113°F)

SPECIFICATIONS

Non-toxic materials, suitable for drinking water.
 Head and ring nut: reinforced polypropylene.
 Bowl: PET.
 O-ring: EPDM.
 Breather-valve: body polypropylene, o-ring EPDM.
 IN/OUT brass threads: CW 614 N brass.

PLUS 3P SX blue housings

HOUSINGS WITH BRASS BSP THREADS

CODE	MODEL	SUITABLE CARTRIDGE	IN/OUT	THREADS	DIMENSIONS mm		
					A	B	C
RA107T112	MEDIUM PLUS 3P MFO SX AB	5"	1/2"	BRASS-BSP	191	133	130
RA107T412	MEDIUM PLUS 3P AFO SX AB	5"	3/4"	BRASS-BSP	191	133	130
RA107T712	MEDIUM PLUS 3P BFO SX AB	5"	1"	BRASS-BSP	197	145	130
RA109T112	JUNIOR PLUS 3P MFO SX AB	7"	1/2"	BRASS-BSP	241	133	130
RA109T412	JUNIOR PLUS 3P AFO SX AB	7"	3/4"	BRASS-BSP	241	133	130
RA109T712	JUNIOR PLUS 3P BFO SX AB	7"	1"	BRASS-BSP	247	145	130
RA111T112	SENIOR PLUS 3P MFO SX AB	10"	1/2"	BRASS-BSP	315	133	130
RA111T412	SENIOR PLUS 3P AFO SX AB	10"	3/4"	BRASS-BSP	315	133	130
RA111T712	SENIOR PLUS 3P BFO SX AB	10"	1"	BRASS-BSP	321	145	130
RA115T112	MASTER PLUS 3P MFO SX AB	20"	1/2"	BRASS-BSP	571	133	130
RA115T412	MASTER PLUS 3P AFO SX AB	20"	3/4"	BRASS-BSP	571	133	130
RA115T712	MASTER PLUS 3P BFO SX AB	20"	1"	BRASS-BSP	577	145	130

HOUSINGS WITH PLASTIC BSP THREADS

CODE	MODEL	SUITABLE CARTRIDGE	IN/OUT	THREADS	DIMENSIONS mm		
					A	B	C
RA107T212	MEDIUM PLUS 3P MFP SX AB	5"	1/2"	PLASTIC-BSP	191	133	130
RA107T512	MEDIUM PLUS 3P AFP SX AB	5"	3/4"	PLASTIC-BSP	191	133	130
RA107T812	MEDIUM PLUS 3P BFP SX AB	5"	1"	PLASTIC-BSP	197	145	130
RA109T212	JUNIOR PLUS 3P MFP SX AB	7"	1/2"	PLASTIC-BSP	241	133	130
RA109T512	JUNIOR PLUS 3P AFP SX AB	7"	3/4"	PLASTIC-BSP	241	133	130
RA109T812	JUNIOR PLUS 3P BFP SX AB	7"	1"	PLASTIC-BSP	247	145	130
RA111T212	SENIOR PLUS 3P MFP SX AB	10"	1/2"	PLASTIC-BSP	315	133	130
RA111T512	SENIOR PLUS 3P AFP SX AB	10"	3/4"	PLASTIC-BSP	315	133	130
RA111T812	SENIOR PLUS 3P BFP SX AB	10"	1"	PLASTIC-BSP	321	145	130
RA115T212	MASTER PLUS 3P MFP SX AB	20"	1/2"	PLASTIC-BSP	571	133	130
RA115T512	MASTER PLUS 3P AFP SX AB	20"	3/4"	PLASTIC-BSP	571	133	130
RA115T812	MASTER PLUS 3P BFP SX AB	20"	1"	PLASTIC-BSP	577	145	130

HOUSINGS WITH PLASTIC NPT THREADS

CODE	MODEL	SUITABLE CARTRIDGE	IN/OUT	THREADS	DIMENSIONS mm		
					A	B	C
RA107T514	MEDIUM PLUS 3P AFP NPT SX AB	5"	3/4"	PLASTIC-NPT	191	133	130
RA107T814	MEDIUM PLUS 3P BFP NPT SX AB	5"	1"	PLASTIC-NPT	197	145	130
RA109T514	JUNIOR PLUS 3P AFP NPT SX AB	7"	3/4"	PLASTIC-NPT	241	133	130
RA109T814	JUNIOR PLUS 3P BFP NPT SX AB	7"	1"	PLASTIC-NPT	247	145	130
RA111T612	SENIOR PLUS 3P AFP NPT SX AB	10"	3/4"	PLASTIC-NPT	315	133	130
RA111T613	SENIOR PLUS 3P BFP NPT SX AB	10"	1"	PLASTIC-NPT	321	145	130
RA115T612	MASTER PLUS 3P AFP NPT SX AB	20"	3/4"	PLASTIC-NPT	571	133	130
RA115T814	MASTER PLUS 3P BFP NPT SX AB	20"	1"	PLASTIC-NPT	577	145	130



PLUS M 3P SX

WORKING CONDITIONS

Max working pressure _____ 8 bar (116 psi)
 Max working temperature _____ 45°C (113°F)

SPECIFICATIONS

Non-toxic materials, suitable for drinking water.
 Head and ring nut: reinforced polypropylene.
 Bowl: PET.
 O-ring: EPDM.
 Breather-valve: body polypropylene, o-ring EPDM.
 IN/OUT brass threads: CW 614 N brass.
 Manometers: radial type, pressure range BAR 0-12, PSI 0-170.

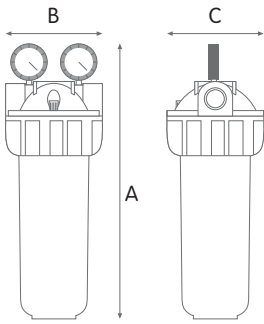

PLUS M 3P SX clear housings with 2 manometers

HOUSINGS WITH BRASS BSP THREADS

CODE	MODEL	SUITABLE CARTRIDGE	IN/OUT	THREADS	DIMENSIONS mm		
					A	B	C
RA107T114	MEDIUM PLUS M 3P MFO SX TS	5"	1/2"	BRASS-BSP	241	133	130
RA107T414	MEDIUM PLUS M 3P AFO SX TS	5"	3/4"	BRASS-BSP	241	133	130
RA107T714	MEDIUM PLUS M 3P BFO SX TS	5"	1"	BRASS-BSP	247	145	130
RA109T114	JUNIOR PLUS M 3P MFO SX TS	7"	1/2"	BRASS-BSP	291	133	130
RA109T414	JUNIOR PLUS M 3P AFO SX TS	7"	3/4"	BRASS-BSP	291	133	130
RA109T714	JUNIOR PLUS M 3P BFO SX TS	7"	1"	BRASS-BSP	297	145	130
RA111T114	SENIOR PLUS M 3P MFO SX TS	10"	1/2"	BRASS-BSP	365	133	130
RA111T414	SENIOR PLUS M 3P AFO SX TS	10"	3/4"	BRASS-BSP	365	133	130
RA111T714	SENIOR PLUS M 3P BFO SX TS	10"	1"	BRASS-BSP	371	145	130
RA115T114	MASTER PLUS M 3P MFO SX TS	20"	1/2"	BRASS-BSP	621	133	130
RA115T414	MASTER PLUS M 3P AFO SX TS	20"	3/4"	BRASS-BSP	621	133	130
RA115T714	MASTER PLUS M 3P BFO SX TS	20"	1"	BRASS-BSP	627	145	130

HOUSINGS WITH PLASTIC NPT THREADS

CODE	MODEL	SUITABLE CARTRIDGE	IN/OUT	THREADS	DIMENSIONS mm		
					A	B	C
RA107T416	MEDIUM PLUS M 3P AFP NPT SX TS	5"	3/4"	PLASTIC-NPT	241	133	130
RA107T716	MEDIUM PLUS M 3P BFP NPT SX TS	5"	1"	PLASTIC-NPT	247	145	130
RA109T416	JUNIOR PLUS M 3P AFP NPT SX TS	7"	3/4"	PLASTIC-NPT	291	133	130
RA109T716	JUNIOR PLUS M 3P BFP NPT SX TS	7"	1"	PLASTIC-NPT	297	145	130
RA111T416	SENIOR PLUS M 3P AFP NPT SX TS	10"	3/4"	PLASTIC-NPT	365	133	130
RA111T716	SENIOR PLUS M 3P BFP NPT SX TS	10"	1"	PLASTIC-NPT	371	145	130
RA115T416	MASTER PLUS M 3P AFP NPT SX TS	20"	3/4"	PLASTIC-NPT	621	133	130
RA115T716	MASTER PLUS M 3P BFP NPT SX TS	20"	1"	PLASTIC-NPT	627	145	130

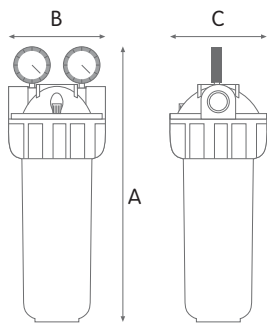

WORKING CONDITIONS

Max working pressure _____ 8 bar (116 psi)
 Max working temperature _____ 45°C (113°F)

SPECIFICATIONS

Non-toxic materials, suitable for drinking water.
 Head and ring nut: reinforced polypropylene.
 Bowl: PET.
 O-ring: EPDM.
 Breather-valve: body polypropylene, o-ring EPDM.
 IN/OUT brass threads: CW 614 N brass.
 Manometers: radial type, pressure range BAR 0-12, PSI 0-170.

PLUS M 3P SX blue housings with 2 manometers

HOUSINGS WITH BRASS BSP THREADS

CODE	MODEL	SUITABLE CARTRIDGE	IN/OUT	THREADS	DIMENSIONS mm		
					A	B	C
RA107T115	MEDIUM PLUS M 3P MFO SX AB	5"	1/2"	BRASS-BSP	241	133	130
RA107T415	MEDIUM PLUS M 3P AFO SX AB	5"	3/4"	BRASS-BSP	241	133	130
RA107T715	MEDIUM PLUS M 3P BFO SX AB	5"	1"	BRASS-BSP	247	145	130
RA109T115	JUNIOR PLUS M 3P MFO SX AB	7"	1/2"	BRASS-BSP	291	133	130
RA109T415	JUNIOR PLUS M 3P AFO SX AB	7"	3/4"	BRASS-BSP	291	133	130
RA109T715	JUNIOR PLUS M 3P BFO SX AB	7"	1"	BRASS-BSP	297	145	130
RA111T115	SENIOR PLUS M 3P MFO SX AB	10"	1/2"	BRASS-BSP	365	133	130
RA111T415	SENIOR PLUS M 3P AFO SX AB	10"	3/4"	BRASS-BSP	365	133	130
RA111T715	SENIOR PLUS M 3P BFO SX AB	10"	1"	BRASS-BSP	371	145	130
RA115T115	MASTER PLUS M 3P MFO SX AB	20"	1/2"	BRASS-BSP	621	133	130
RA115T415	MASTER PLUS M 3P AFO SX AB	20"	3/4"	BRASS-BSP	621	133	130
RA115T715	MASTER PLUS M 3P BFO SX AB	20"	1"	BRASS-BSP	627	145	130

HOUSINGS WITH PLASTIC NPT THREADS

CODE	MODEL	SUITABLE CARTRIDGE	IN/OUT	THREADS	DIMENSIONS mm		
					A	B	C
RA107T417	MEDIUM PLUS M 3P AFP NPT SX AB	5"	3/4"	PLASTIC-NPT	241	133	130
RA107T717	MEDIUM PLUS M 3P BFP NPT SX AB	5"	1"	PLASTIC-NPT	247	145	130
RA109T417	JUNIOR PLUS M 3P AFP NPT SX AB	7"	3/4"	PLASTIC-NPT	291	133	130
RA109T717	JUNIOR PLUS M 3P BFP NPT SX AB	7"	1"	PLASTIC-NPT	297	145	130
RA111T417	SENIOR PLUS M 3P AFP NPT SX AB	10"	3/4"	PLASTIC-NPT	365	133	130
RA111T717	SENIOR PLUS M 3P BFP NPT SX AB	10"	1"	PLASTIC-NPT	371	145	130
RA115T417	MASTER PLUS M 3P AFP NPT SX AB	20"	3/4"	PLASTIC-NPT	621	133	130
RA115T717	MASTER PLUS M 3P BFP NPT SX AB	20"	1"	PLASTIC-NPT	627	145	130



DUPLEX PLUS 3P SX

WORKING CONDITIONS

Max working pressure _____ 8 bar (116 psi)
 Max working temperature _____ 45°C (113°F)

SPECIFICATIONS

Non-toxic materials, suitable for drinking water.
 Head and ring nut: reinforced polypropylene.
 Bowl: PET.
 O-ring: EPDM.
 Breather-valve: body polypropylene, o-ring EPDM.
 IN/OUT brass threads: CW 614 N brass.

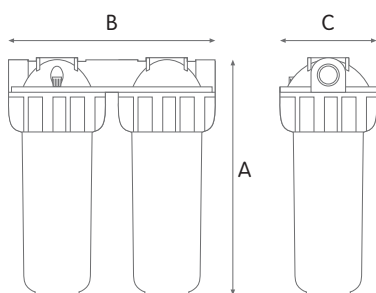

DUPLEX PLUS 3P SX clear housings

HOUSINGS WITH BRASS BSP THREADS

CODE	MODEL	SUITABLE CARTRIDGE	IN/OUT	THREADS	DIMENSIONS mm		
					A	B	C
RA108T411	MEDIUM DUPLEX PLUS 3P AFO SX TS	5"	3/4"	BRASS-BSP	191	275	130
RA108T711	MEDIUM DUPLEX PLUS 3P BFO SX TS	5"	1"	BRASS-BSP	191	275	130
RA110T411	JUNIOR DUPLEX PLUS 3P AFO SX TS	7"	3/4"	BRASS-BSP	241	275	130
RA110T711	JUNIOR DUPLEX PLUS 3P BFO SX TS	7"	1"	BRASS-BSP	241	275	130
RA112T411	SENIOR DUPLEX PLUS 3P AFO SX TS	10"	3/4"	BRASS-BSP	315	275	130
RA112T711	SENIOR DUPLEX PLUS 3P BFO SX TS	10"	1"	BRASS-BSP	315	275	130
RA116T411	MASTER DUPLEX PLUS 3P AFO SX TS	20"	3/4"	BRASS-BSP	571	275	130
RA116T711	MASTER DUPLEX PLUS 3P BFO SX TS	20"	1"	BRASS-BSP	571	275	130

HOUSINGS WITH PLASTIC BSP THREADS

CODE	MODEL	SUITABLE CARTRIDGE	IN/OUT	THREADS	DIMENSIONS mm		
					A	B	C
RA108T511	MEDIUM DUPLEX PLUS 3P AFP SX TS	5"	3/4"	PLASTIC-BSP	191	275	130
RA108T811	MEDIUM DUPLEX PLUS 3P BFP SX TS	5"	1"	PLASTIC-BSP	191	275	130
RA110T511	JUNIOR DUPLEX PLUS 3P AFP SX TS	7"	3/4"	PLASTIC-BSP	241	275	130
RA110T811	JUNIOR DUPLEX PLUS 3P BFP SX TS	7"	1"	PLASTIC-BSP	241	275	130
RA112T511	SENIOR DUPLEX PLUS 3P AFP SX TS	10"	3/4"	PLASTIC-BSP	315	275	130
RA112T811	SENIOR DUPLEX PLUS 3P BFP SX TS	10"	1"	PLASTIC-BSP	315	275	130
RA116T511	MASTER DUPLEX PLUS 3P AFP SX TS	20"	3/4"	PLASTIC-BSP	571	275	130
RA116T811	MASTER DUPLEX PLUS 3P BFP SX TS	20"	1"	PLASTIC-BSP	571	275	130

HOUSINGS WITH PLASTIC NPT THREADS

CODE	MODEL	SUITABLE CARTRIDGE	IN/OUT	THREADS	DIMENSIONS mm		
					A	B	C
RA108T513	MEDIUM DUPLEX PLUS 3P AFP NPT SX TS	5"	3/4"	PLASTIC-NPT	191	275	130
RA110T513	JUNIOR DUPLEX PLUS 3P AFP NPT SX TS	7"	3/4"	PLASTIC-NPT	241	275	130
RA112T611	SENIOR DUPLEX PLUS 3P AFP NPT SX TS	10"	3/4"	PLASTIC-NPT	315	275	130
RA116T611	MASTER DUPLEX PLUS 3P AFP NPT SX TS	20"	3/4"	PLASTIC-NPT	571	275	130

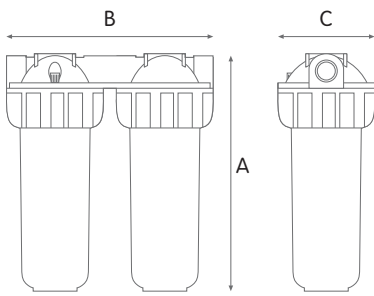

WORKING CONDITIONS

Max working pressure _____ 8 bar (116 psi)
 Max working temperature _____ 45°C (113°F)

SPECIFICATIONS

Non-toxic materials, suitable for drinking water.
 Head and ring nut: reinforced polypropylene.
 Bowl: PET.
 O-ring: EPDM.
 Breather-valve: body polypropylene, o-ring EPDM.
 IN/OUT brass threads: CW 614 N brass.

DUPLEX PLUS 3P SX blue housings

HOUSINGS WITH BRASS BSP THREADS

CODE	MODEL	SUITABLE CARTRIDGE	IN/OUT	THREADS	DIMENSIONS mm		
					A	B	C
RA108T412	MEDIUM DUPLEX PLUS 3P AFO SX AB	5"	3/4"	BRASS-BSP	191	275	130
RA108T712	MEDIUM DUPLEX PLUS 3P BFO SX AB	5"	1"	BRASS-BSP	191	275	130
RA110T412	JUNIOR DUPLEX PLUS 3P AFO SX AB	7"	3/4"	BRASS-BSP	241	275	130
RA110T712	JUNIOR DUPLEX PLUS 3P BFO SX AB	10"	1"	BRASS-BSP	241	275	130
RA112T412	SENIOR DUPLEX PLUS 3P AFO SX AB	10"	3/4"	BRASS-BSP	315	275	130
RA112T712	SENIOR DUPLEX PLUS 3P BFO SX AB	10"	1"	BRASS-BSP	315	275	130
RA116T412	MASTER DUPLEX PLUS 3P AFO SX AB	20"	3/4"	BRASS-BSP	571	275	130
RA116T712	MASTER DUPLEX PLUS 3P BFO SX AB	20"	1"	BRASS-BSP	571	275	130

HOUSINGS WITH PLASTIC BSP THREADS

CODE	MODEL	SUITABLE CARTRIDGE	IN/OUT	THREADS	DIMENSIONS mm		
					A	B	C
RA108T512	MEDIUM DUPLEX PLUS 3P AFP SX AB	5"	3/4"	PLASTIC-BSP	191	275	130
RA108T812	MEDIUM DUPLEX PLUS 3P BFP SX AB	5"	1"	PLASTIC-BSP	191	275	130
RA110T512	JUNIOR DUPLEX PLUS 3P AFP SX AB	7"	3/4"	PLASTIC-BSP	241	275	130
RA110T812	JUNIOR DUPLEX PLUS 3P BFP SX AB	10"	1"	PLASTIC-BSP	241	275	130
RA112T512	SENIOR DUPLEX PLUS 3P AFP SX AB	10"	3/4"	PLASTIC-BSP	315	275	130
RA112T812	SENIOR DUPLEX PLUS 3P BFP SX AB	10"	1"	PLASTIC-BSP	315	275	130
RA116T512	MASTER DUPLEX PLUS 3P AFP SX AB	20"	3/4"	PLASTIC-BSP	571	275	130
RA116T812	MASTER DUPLEX PLUS 3P BFP SX AB	20"	1"	PLASTIC-BSP	571	275	130

HOUSINGS WITH PLASTIC NPT THREADS

CODE	MODEL	SUITABLE CARTRIDGE	IN/OUT	THREADS	DIMENSIONS mm		
					A	B	C
RA108T514	MEDIUM DUPLEX PLUS 3P AFP NPT SX AB	5"	3/4"	PLASTIC-NPT	191	275	130
RA110T514	JUNIOR DUPLEX PLUS 3P AFP NPT SX AB	7"	3/4"	PLASTIC-NPT	241	275	130
RA112T612	SENIOR DUPLEX PLUS 3P AFP NPT SX AB	10"	3/4"	PLASTIC-NPT	315	275	130
RA116T612	MASTER DUPLEX PLUS 3P AFP NPT SX AB	20"	3/4"	PLASTIC-NPT	571	275	130



PLUS 2P SX

WORKING CONDITIONS

Max working pressure _____ 8 bar (116 psi)
 Max working temperature _____ 45°C (113°F)

SPECIFICATIONS

Non-toxic materials, suitable for drinking water.
 Head: reinforced polypropylene.
 Bowl: SAN.
 O-ring: EPDM.
 Breather-valve: body polypropylene, o-ring EPDM.
 IN/OUT brass threads: CW 614 N brass.

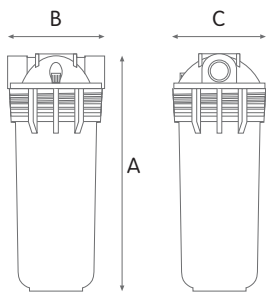

PLUS 2P SX clear housings

HOUSINGS WITH BRASS BSP THREADS

CODE	MODEL	SUITABLE CARTRIDGE	IN/OUT	THREADS	DIMENSIONS mm		
					A	B	C
PA117P111	CADET PLUS 2P MFO SX AS	4"	1/2"	BRASS-BSP	169	133	130
PA117P411	CADET PLUS 2P AFO SX AS	4"	3/4"	BRASS-BSP	169	133	130
PA117P711	CADET PLUS 2P BFO SX AS	4"	1"	BRASS-BSP	173	145	130
PA119P111	JUNIOR PLUS 2P MFO SX AS	7"	1/2"	BRASS-BSP	241	133	130
PA119P411	JUNIOR PLUS 2P AFO SX AS	7"	3/4"	BRASS-BSP	241	133	130
PA119P711	JUNIOR PLUS 2P BFO SX AS	7"	1"	BRASS-BSP	247	145	130
PA121P111	SENIOR PLUS 2P MFO SX AS	10"	1/2"	BRASS-BSP	315	133	130
PA121P411	SENIOR PLUS 2P AFO SX AS	10"	3/4"	BRASS-BSP	315	133	130
PA121P711	SENIOR PLUS 2P BFO SX AS	10"	1"	BRASS-BSP	321	145	130

HOUSINGS WITH PLASTIC BSP THREADS

CODE	MODEL	SUITABLE CARTRIDGE	IN/OUT	THREADS	DIMENSIONS mm		
					A	B	C
PA117P211	CADET PLUS 2P MFP SX AS	4"	1/2"	PLASTIC-BSP	169	133	130
PA117P511	CADET PLUS 2P AFP SX AS	4"	3/4"	PLASTIC-BSP	169	133	130
PA117P811	CADET PLUS 2P BFP SX AS	4"	1"	PLASTIC-BSP	173	145	130
PA119P211	JUNIOR PLUS 2P MFP SX AS	7"	1/2"	PLASTIC-BSP	241	133	130
PA119P511	JUNIOR PLUS 2P AFP SX AS	7"	3/4"	PLASTIC-BSP	241	133	130
PA119P811	JUNIOR PLUS 2P BFP SX AS	7"	1"	PLASTIC-BSP	247	145	130
PA121P211	SENIOR PLUS 2P MFP SX AS	10"	1/2"	PLASTIC-BSP	315	133	130
PA121P511	SENIOR PLUS 2P AFP SX AS	10"	3/4"	PLASTIC-BSP	315	133	130
PA121P811	SENIOR PLUS 2P BFP SX AS	10"	1"	PLASTIC-BSP	321	145	130

HOUSINGS WITH PLASTIC NPT THREADS

CODE	MODEL	SUITABLE CARTRIDGE	IN/OUT	THREADS	DIMENSIONS mm		
					A	B	C
RA117P516	CADET PLUS 2P AFP NPT SX AS	4"	3/4"	PLASTIC-NPT	169	133	130
RA117P816	CADET PLUS 2P BFP NPT SX AS	4"	1"	PLASTIC-NPT	173	145	130
RA119P516	JUNIOR PLUS 2P AFP NPT SX AS	7"	3/4"	PLASTIC-NPT	241	133	130
RA119P816	JUNIOR PLUS 2P BFP NPT SX AS	7"	1"	PLASTIC-NPT	247	145	130
RA121P516	SENIOR PLUS 2P AFP NPT SX AS	10"	3/4"	PLASTIC-NPT	315	133	130
RA121P816	SENIOR PLUS 2P BFP NPT SX AS	10"	1"	PLASTIC-NPT	321	145	130

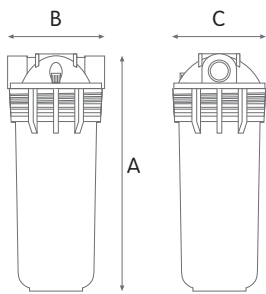

WORKING CONDITIONS

Max working pressure _____ 8 bar (116 psi)
 Max working temperature _____ 45°C (113°F)

SPECIFICATIONS

Non-toxic materials, suitable for drinking water.
 Head: reinforced polypropylene.
 Bowl: reinforced polypropylene.
 O-ring: EPDM.
 Breather-valve: body polypropylene, o-ring EPDM.
 IN/OUT brass threads: CW 614 N brass.

PLUS 2P SX blue housings

HOUSINGS WITH BRASS BSP THREADS

CODE	MODEL	SUITABLE CARTRIDGE	IN/OUT	THREADS	DIMENSIONS mm		
					A	B	C
PA117P112	CADET PLUS 2P MFO SX AB	4"	1/2"	BRASS-BSP	169	133	130
PA117P412	CADET PLUS 2P AFO SX AB	4"	3/4"	BRASS-BSP	169	133	130
PA117P712	CADET PLUS 2P BFO SX AB	4"	1"	BRASS-BSP	173	145	130
PA119P112	JUNIOR PLUS 2P MFO SX AB	7"	1/2"	BRASS-BSP	241	133	130
PA119P412	JUNIOR PLUS 2P AFO SX AB	7"	3/4"	BRASS-BSP	241	133	130
PA119P712	JUNIOR PLUS 2P BFO SX AB	7"	1"	BRASS-BSP	247	145	130
PA121P112	SENIOR PLUS 2P MFO SX AB	10"	1/2"	BRASS-BSP	315	133	130
PA121P412	SENIOR PLUS 2P AFO SX AB	10"	3/4"	BRASS-BSP	315	133	130
PA121P712	SENIOR PLUS 2P BFO SX AB	10"	1"	BRASS-BSP	321	145	130

HOUSINGS WITH PLASTIC BSP THREADS

CODE	MODEL	SUITABLE CARTRIDGE	IN/OUT	THREADS	DIMENSIONS mm		
					A	B	C
PA117P212	CADET PLUS 2P MFP SX AB	4"	1/2"	PLASTIC-BSP	169	133	130
PA117P512	CADET PLUS 2P AFP SX AB	4"	3/4"	PLASTIC-BSP	169	133	130
RA117P812	CADET PLUS 2P BFP SX AB	4"	1"	PLASTIC-BSP	173	145	130
PA119P212	JUNIOR PLUS 2P MFP SX AB	7"	1/2"	PLASTIC-BSP	241	133	130
PA119P512	JUNIOR PLUS 2P AFP SX AB	7"	3/4"	PLASTIC-BSP	241	133	130
PA119P812	JUNIOR PLUS 2P BFP SX AB	7"	1"	PLASTIC-BSP	247	145	130
PA121P212	SENIOR PLUS 2P MFP SX AB	10"	1/2"	PLASTIC-BSP	315	133	130
PA121P512	SENIOR PLUS 2P AFP SX AB	10"	3/4"	PLASTIC-BSP	315	133	130
PA121P812	SENIOR PLUS 2P BFP SX AB	10"	1"	PLASTIC-BSP	321	145	130

HOUSINGS WITH PLASTIC NPT THREADS

CODE	MODEL	SUITABLE CARTRIDGE	IN/OUT	THREADS	DIMENSIONS mm		
					A	B	C
RA117P517	CADET PLUS 2P AFP NPT SX AB	4"	3/4"	PLASTIC-NPT	169	133	130
RA117P817	CADET PLUS 2P BFP NPT SX AB	4"	1"	PLASTIC-NPT	173	145	130
RA119P517	JUNIOR PLUS 2P AFP NPT SX AB	7"	3/4"	PLASTIC-NPT	241	133	130
RA119P817	JUNIOR PLUS 2P BFP NPT SX AB	7"	1"	PLASTIC-NPT	247	145	130
RA121P517	SENIOR PLUS 2P AFP NPT SX AB	10"	3/4"	PLASTIC-NPT	315	133	130
RA121P817	SENIOR PLUS 2P BFP NPT SX AB	10"	1"	PLASTIC-NPT	321	145	130



PLUS M 2P SX

WORKING CONDITIONS

Max working pressure _____ 8 bar (116 psi)
 Max working temperature _____ 45°C (113°F)

SPECIFICATIONS

Non-toxic materials, suitable for drinking water.
 Head: reinforced polypropylene.
 Bowl: SAN.
 O-ring: EPDM.
 Breather-valve: body polypropylene, o-ring EPDM.
 IN/OUT brass threads: CW 614 N brass.
 Manometers: radial type, pressure range BAR 0-12, PSI 0-170.

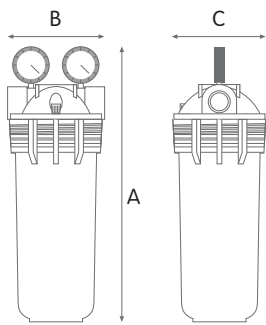

PLUS M 2P SX clear housings with 2 manometers

HOUSINGS WITH BRASS BSP THREADS

CODE	MODEL	SUITABLE CARTRIDGE	IN/OUT	THREADS	DIMENSIONS mm		
					A	B	C
RA117P114	CADET PLUS M 2P MFO SX AS	4"	1/2"	BRASS-BSP	219	133	130
RA117P414	CADET PLUS M 2P AFO SX AS	4"	3/4"	BRASS-BSP	219	133	130
RA117P714	CADET PLUS M 2P BFO SX AS	4"	1"	BRASS-BSP	225	145	130
RA119P114	JUNIOR PLUS M 2P MFO SX AS	7"	1/2"	BRASS-BSP	291	133	130
RA119P414	JUNIOR PLUS M 2P AFO SX AS	7"	3/4"	BRASS-BSP	291	133	130
RA119P714	JUNIOR PLUS M 2P BFO SX AS	7"	1"	BRASS-BSP	297	145	130
RA121P114	SENIOR PLUS M 2P MFO SX AS	10"	1/2"	BRASS-BSP	365	133	130
RA121P414	SENIOR PLUS M 2P AFO SX AS	10"	3/4"	BRASS-BSP	365	133	130
RA121P714	SENIOR PLUS M 2P BFO SX AS	10"	1"	BRASS-BSP	371	145	130

HOUSINGS WITH PLASTIC NPT THREADS

CODE	MODEL	SUITABLE CARTRIDGE	IN/OUT	THREADS	DIMENSIONS mm		
					A	B	C
RA117P518	CADET PLUS M 2P AFP NPT SX AS	4"	3/4"	PLASTIC-NPT	219	133	130
RA117P818	CADET PLUS M 2P BFP NPT SX AS	4"	1"	PLASTIC-NPT	225	145	130
RA119P518	JUNIOR PLUS M 2P AFP NPT SX AS	7"	3/4"	PLASTIC-NPT	291	133	130
RA119P818	JUNIOR PLUS M 2P BFP NPT SX AS	7"	1"	PLASTIC-NPT	297	145	130
RA121P518	SENIOR PLUS M 2P AFP NPT SX AS	10"	3/4"	PLASTIC-NPT	365	133	130
RA121P818	SENIOR PLUS M 2P BFP NPT SX AS	10"	1"	PLASTIC-NPT	371	145	130

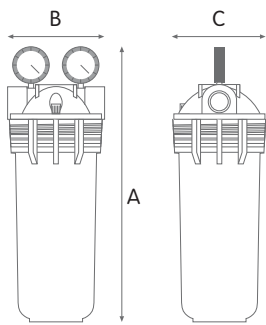

WORKING CONDITIONS

Max working pressure _____ 8 bar (116 psi)
 Max working temperature _____ 45°C (113°F)

SPECIFICATIONS

Non-toxic materials, suitable for drinking water.
 Head: reinforced polypropylene.
 Bowl: reinforced polypropylene.
 O-ring: EPDM.
 Breather-valve: body polypropylene, o-ring EPDM.
 IN/OUT brass threads: CW 614 N brass.
 Manometers: radial type, pressure range BAR 0-12, PSI 0-170.

PLUS M 2P SX blue housings with 2 manometers

HOUSINGS WITH BRASS BSP THREADS

CODE	MODEL	SUITABLE CARTRIDGE	IN/OUT	THREADS	DIMENSIONS mm		
					A	B	C
RA117P115	CADET PLUS M 2P MFO SX AB	4"	1/2"	BRASS-BSP	219	133	130
RA117P415	CADET PLUS M 2P AFO SX AB	4"	3/4"	BRASS-BSP	219	133	130
RA117P715	CADET PLUS M 2P BFO SX AB	4"	1"	BRASS-BSP	225	145	130
RA119P115	JUNIOR PLUS M 2P MFO SX AB	7"	1/2"	BRASS-BSP	291	133	130
RA119P415	JUNIOR PLUS M 2P AFO SX AB	7"	3/4"	BRASS-BSP	291	133	130
RA119P715	JUNIOR PLUS M 2P BFO SX AB	7"	1"	BRASS-BSP	297	145	130
RA121P115	SENIOR PLUS M 2P MFO SX AB	10"	1/2"	BRASS-BSP	365	133	130
RA121P415	SENIOR PLUS M 2P AFO SX AB	10"	3/4"	BRASS-BSP	365	133	130
RA121P715	SENIOR PLUS M 2P BFO SX AB	10"	1"	BRASS-BSP	371	145	130

HOUSINGS WITH PLASTIC NPT THREADS

CODE	MODEL	SUITABLE CARTRIDGE	IN/OUT	THREADS	DIMENSIONS mm		
					A	B	C
RA117P519	CADET PLUS M 2P AFP NPT SX AB	4"	3/4"	PLASTIC-NPT	219	133	130
RA117P819	CADET PLUS M 2P BFP NPT SX AB	4"	1"	PLASTIC-NPT	225	145	130
RA119P519	JUNIOR PLUS M 2P AFP NPT SX AB	7"	3/4"	PLASTIC-NPT	291	133	130
RA119P819	JUNIOR PLUS M 2P BFP NPT SX AB	7"	1"	PLASTIC-NPT	297	145	130
RA121P519	SENIOR PLUS M 2P AFP NPT SX AB	10"	3/4"	PLASTIC-NPT	365	133	130
RA121P819	SENIOR PLUS M 2P BFP NPT SX AB	10"	1"	PLASTIC-NPT	371	145	130



DUPLEX PLUS 2P SX

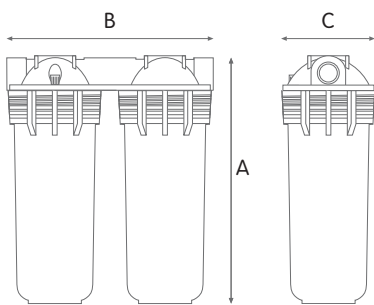

WORKING CONDITIONS

Max working pressure _____ 8 bar (116 psi)
 Max working temperature _____ 45°C (113°F)

SPECIFICATIONS

Non-toxic materials, suitable for drinking water.
 Head: reinforced polypropylene.
 Bowl: SAN.
 O-ring: EPDM.
 Breather-valve: body polypropylene, o-ring EPDM.
 IN/OUT brass threads: CW 614 N brass.

DUPLEX PLUS 2P SX clear housings

HOUSINGS WITH BRASS BSP THREADS

CODE	MODEL	SUITABLE CARTRIDGE	IN/OUT	THREADS	DIMENSIONS mm		
					A	B	C
PA118P411	CADET DUPLEX PLUS 2P AFO SX AS	4"	3/4"	BRASS-BSP	169	275	130
PA118P711	CADET DUPLEX PLUS 2P BFO SX AS	4"	1"	BRASS-BSP	169	275	130
PA120P411	JUNIOR DUPLEX PLUS 2P AFO SX AS	7"	3/4"	BRASS-BSP	241	275	130
PA120P711	JUNIOR DUPLEX PLUS 2P BFO SX AS	7"	1"	BRASS-BSP	241	275	130
PA122P411	SENIOR DUPLEX PLUS 2P AFO SX AS	10"	3/4"	BRASS-BSP	315	275	130
PA122P711	SENIOR DUPLEX PLUS 2P BFO SX AS	10"	1"	BRASS-BSP	315	275	130

HOUSINGS WITH PLASTIC BSP THREADS

CODE	MODEL	SUITABLE CARTRIDGE	IN/OUT	THREADS	DIMENSIONS mm		
					A	B	C
PA118P511	CADET DUPLEX PLUS 2P AFP SX AS	4"	3/4"	PLASTIC-BSP	169	275	130
RA118P811	CADET DUPLEX PLUS 2P BFP SX AS	4"	1"	PLASTIC-BSP	169	275	130
PA120P511	JUNIOR DUPLEX PLUS 2P AFP SX AS	7"	3/4"	PLASTIC-BSP	241	275	130
RA120P811	JUNIOR DUPLEX PLUS 2P BFP SX AS	7"	1"	PLASTIC-BSP	241	275	130
PA122P511	SENIOR DUPLEX PLUS 2P AFP SX AS	10"	3/4"	PLASTIC-BSP	315	275	130
RA122P811	SENIOR DUPLEX PLUS 2P BFP SX AS	10"	1"	PLASTIC-BSP	315	275	130

HOUSINGS WITH PLASTIC NPT THREADS

CODE	MODEL	SUITABLE CARTRIDGE	IN/OUT	THREADS	DIMENSIONS mm		
					A	B	C
RA118P513	CADET DUPLEX PLUS 2P AFP NPT SX AS	4"	3/4"	PLASTIC-NPT	169	275	130
RA120P513	JUNIOR DUPLEX PLUS 2P AFP NPT SX AS	7"	3/4"	PLASTIC-NPT	241	275	130
RA122P513	SENIOR DUPLEX PLUS 2P AFP NPT SX AS	10"	3/4"	PLASTIC-NPT	315	275	130

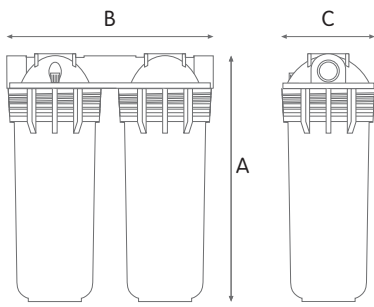

WORKING CONDITIONS

Max working pressure _____ 8 bar (116 psi)
 Max working temperature _____ 45°C (113°F)

SPECIFICATIONS

Non-toxic materials, suitable for drinking water.
 Head: reinforced polypropylene.
 Bowl: reinforced polypropylene.
 O-ring: EPDM.
 Breather-valve: body polypropylene, o-ring EPDM.
 IN/OUT brass threads: CW 614 N brass.

DUPLEX PLUS 2P SX blue housings

HOUSINGS WITH BRASS BSP THREADS

CODE	MODEL	SUITABLE CARTRIDGE	IN/OUT	THREADS	DIMENSIONS mm		
					A	B	C
PA118P412	CADET DUPLEX PLUS 2P AFO SX AB	4"	3/4"	BRASS-BSP	169	275	130
RA118P712	CADET DUPLEX PLUS 2P BFO SX AB	4"	1"	BRASS-BSP	169	275	130
PA120P412	JUNIOR DUPLEX PLUS 2P AFO SX AB	7"	3/4"	BRASS-BSP	241	275	130
RA120P712	JUNIOR DUPLEX PLUS 2P BFO SX AB	10"	1"	BRASS-BSP	241	275	130
PA122P412	SENIOR DUPLEX PLUS 2P AFO SX AB	10"	3/4"	BRASS-BSP	315	275	130
RA122P712	SENIOR DUPLEX PLUS 2P BFO SX AB	10"	1"	BRASS-BSP	315	275	130

HOUSINGS WITH PLASTIC BSP THREADS

CODE	MODEL	SUITABLE CARTRIDGE	IN/OUT	THREADS	DIMENSIONS mm		
					A	B	C
PA118P512	CADET DUPLEX PLUS 2P AFP SX AB	4"	3/4"	PLASTIC-BSP	169	275	130
RA118P812	CADET DUPLEX PLUS 2P BFP SX AB	4"	1"	PLASTIC-BSP	169	275	130
PA120P512	JUNIOR DUPLEX PLUS 2P AFP SX AB	7"	3/4"	PLASTIC-BSP	241	275	130
RA120P812	JUNIOR DUPLEX PLUS 2P BFP SX AB	10"	1"	PLASTIC-BSP	241	275	130
PA122P512	SENIOR DUPLEX PLUS 2P AFP SX AB	10"	3/4"	PLASTIC-BSP	315	275	130
RA122P812	SENIOR DUPLEX PLUS 2P BFP SX AB	10"	1"	PLASTIC-BSP	315	275	130

HOUSINGS WITH PLASTIC NPT THREADS

CODE	MODEL	SUITABLE CARTRIDGE	IN/OUT	THREADS	DIMENSIONS mm		
					A	B	C
RA118P514	CADET DUPLEX PLUS 2P AFP NPT SX AB	4"	3/4"	PLASTIC-NPT	169	275	130
RA120P514	JUNIOR DUPLEX PLUS 2P AFP NPT SX AB	7"	3/4"	PLASTIC-NPT	241	275	130
RA122P514	SENIOR DUPLEX PLUS 2P AFP NPT SX AB	10"	3/4"	PLASTIC-NPT	315	275	130

Ташев-Галвинг ООД
www.tashev-galving.com

"water is the driver of nature"
Leonardo Da Vinci



ATLAS FILTRI[®] is a registered trade mark of ATLAS FILTRI srl.
Unauthorized use of the registered trade mark
is strictly forbidden and legally persecuted.
Images and texts are property of ATLAS FILTRI srl,
which reserves the rights to change
products design and specification without prior notice.

ATLAS FILTRI s.r.l.
Via del Santo 227, I-35010 Limena, Italy.
Tel. +39.049.76.90.55 Fax +39.049.76.99.94
www.atlasfiltri.com